

## ALO 177-(x)M

### Accumulating magazine for band saw blades

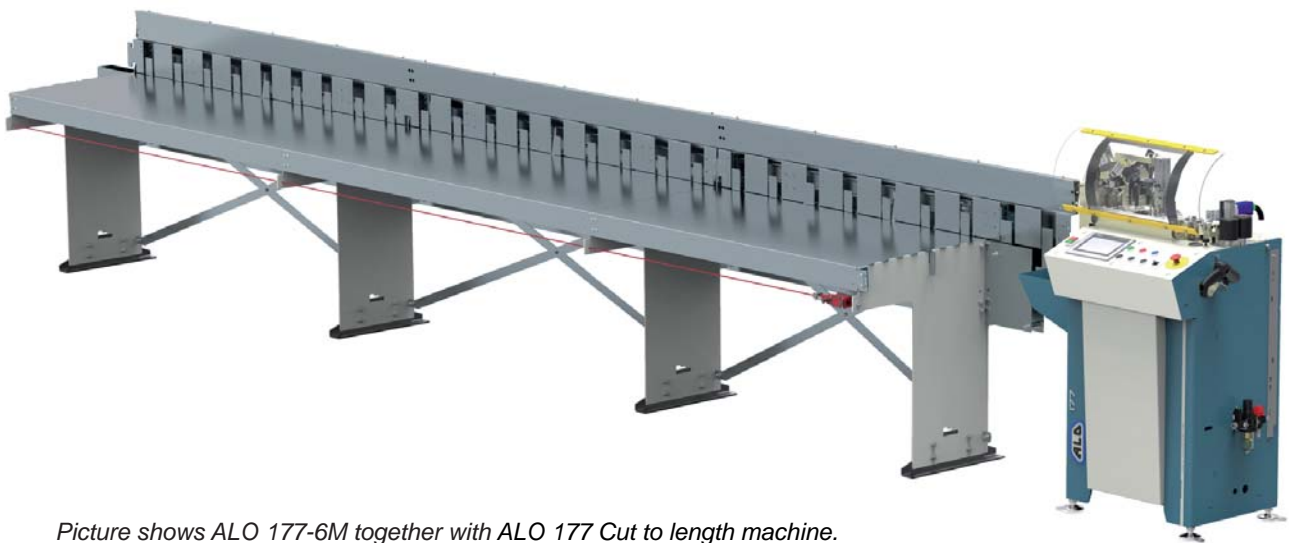

Picture shows ALO 177-6M together with ALO 177 Cut to length machine.

#### ALO 177-xM

The best way to collect your band saw blades after a cut to length machine is to use one of ALO's magazine. The magazine makes the process after the cut to length easy and gather the blades in a safe way. Using a magazine minimizing the risk of damaging the teeth of the saw blade.

ALO 177-xM will allow the user to utilize more of the ALO CTL operation speed and production capacity. The blade is fed out from the CTL machine into a pneumatically operated feed out tray.

When the cut is performed, the blade are dropped and an automatic accumulating motion stacks the blades standing with teeth up. The wide collect tray can be used as a storing surface allowing room for several cutting orders/batches.

It is easy find the right length of the magazine that your production needs. With two meters sections, the magazine can be added up to a desired length.

#### TECHNICAL SPECIFICATION:

|            |              |                    |
|------------|--------------|--------------------|
| 177-model: | Band width:  | 12 - 100mm         |
|            | Band length: | 2m- no upper limit |

*Two meter sections can be added up to a desired length  
(x=length in meter, example 177-12M)*